

BESLAG VOOR ZELFDRAGEND SCHUIFHEK

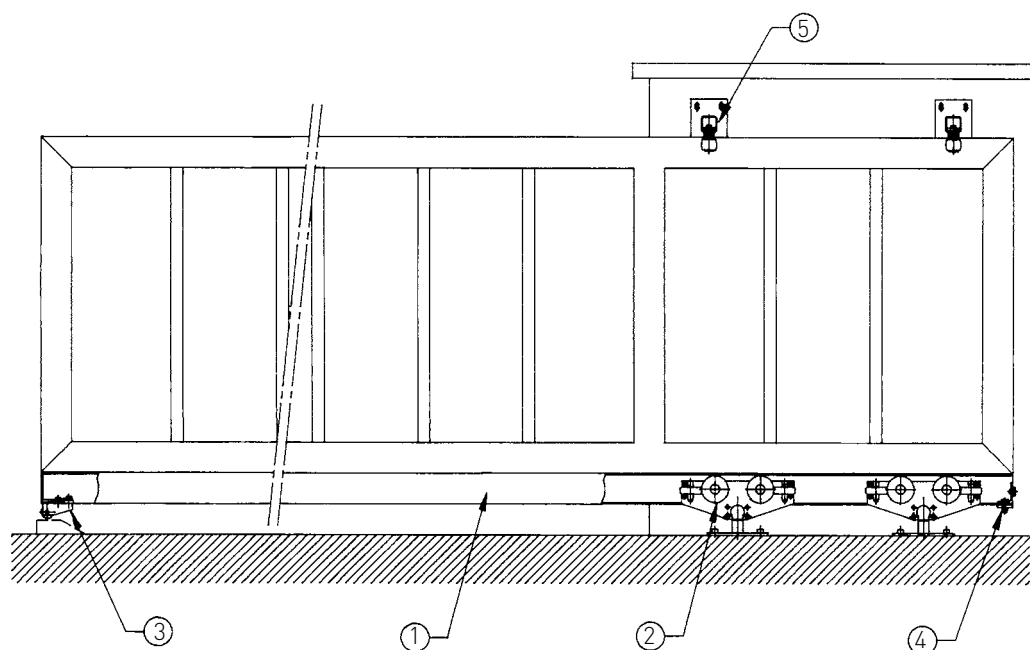

INHOUD

INLEIDING	3
ROLSTELSELS	4
GELEIDERS EN STOPPERS	5
PROFIELEN	6
BEVESTIGINGSMOGELIJKHEDEN	7
FUNDAMENT	8
SAMENBOUW SERIE 240.00	9
SAMENBOUW SERIE 250.000	10
SAMENBOUW SERIE 260.000	11
MINIMUM VERLENGSTUK	12
HEKCONSTRUCTIE - BELASTINGSCOËFFICIËNT	13
RICHTWAARDEN HEKCONSTRUCTIE	14
AUTOMATISATIE	22



1. Profiel
2. Rolstelsel
3. Eindstopper met steunrol
4. Eindstopper
5. Geleider

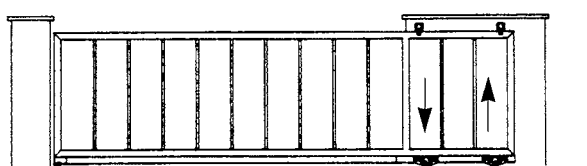

GESLOTEN

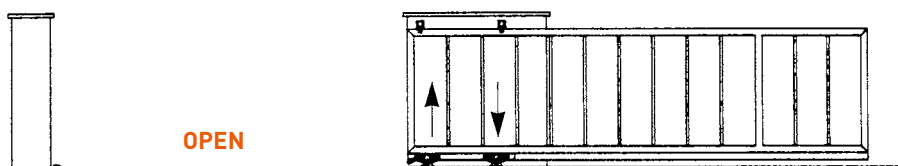

OPEN

Bij een zelfdragend schuifhek worden twee rolstelsels op een fundamente (naast de doorgang) verankerd. Het hek en de looprail vormen één geheel. De looprail schuift over de vaste rolstelsels. Wanneer het hek gesloten is, drukt de looprail naar beneden op de eerste rol en naar boven op de tweede rol (zie tekening). Op deze wijze wordt het hek zelfdragend. In open stand bekomt men de omgekeerde situatie.

VOORDELEN

- **Perfect** vloeiende beweging van uw hek in een volledige **vrije** doorgang.
- Geen onderhoud; met **ROB** werkt u **efficiënt**.
- **Comfort**: automatisatie en afstandsbediening behoren tot het gamma.
- Ook in het langer en **zwaar** hekwerk bouwde **ROB** een stevige reputatie op.
- **Onbegrensde** materiaalkeuze: hout, metaal of aluminium: **ROB** past zich aan!
- De montage is **eenvoudig**: met **ROB** wint u tijd!

244.130
254.130

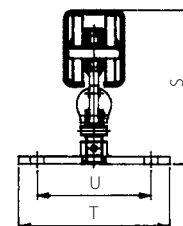
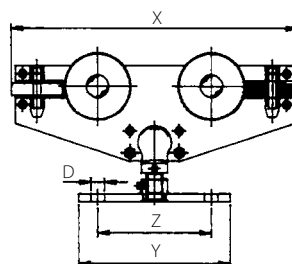
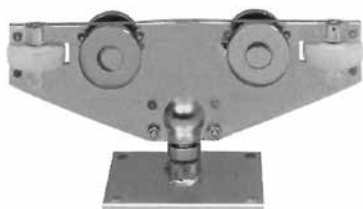

264.130

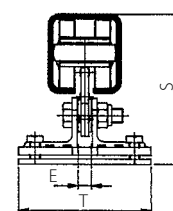
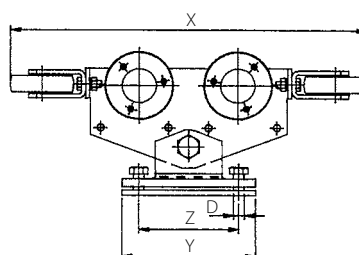

264.150

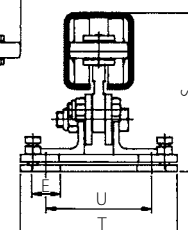
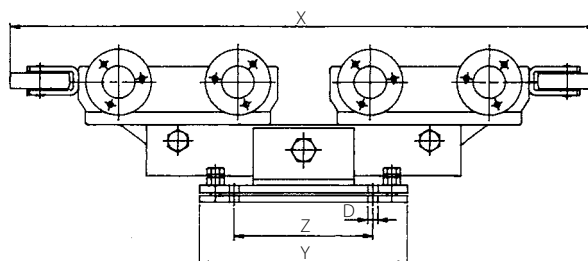
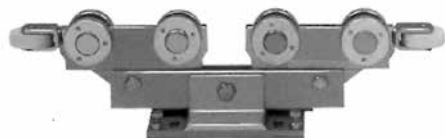

Ref.	S (mm)	T (mm)	U (mm)	D (mm)	E (mm)	X (mm)	Y (mm)	Z (mm)	Gewicht (kg)
244.130	min.178 max.186	125	100	13	-	375	160	135	5,200
254.130	min.195 max.203	200	150	18	-	380	200	150	8,85
264.130	225	200	-	18	38	533	200	150	20
264.150	246	250	170	21	42	933	330	220	50

Om in alle omstandigheden de eventuele helling van het profiel op te vangen zonder dat er een remmingseffect mag optreden, zijn alle rollen kantelbaar om hun as. De verticale rolschijven zijn allen onafhankelijk draaiend, gemonteerd op kogellagers, stofvrij en gesmeerd voor levensduur. De horizontale rollen, die het vloten van het hek moeten opvangen, zijn vervaardigd uit kunststof. De rollen **244.130** en **254.130** zijn 8mm regelbaar in de hoogte. Voor de hoogteregeling van de rollen **264.130** en **264.150** wordt gebruik gemaakt van stelbouten en een tegenplaat.

GELEIDERS EN STOPPERS



158.760.09
(Ø 60mm)
(stalen lager)

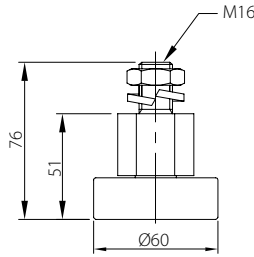

Aan de bovenkant van het hek, op de plaats waar zich de looprollen bevinden, schuift het hek tussen minimum 2 geleidrollen. Deze geleidrollen beletten dat het hek kan omkantelen of tegen de muur kan wrijven.



259.150/1
(inclusief draagstukken 137.310.3)

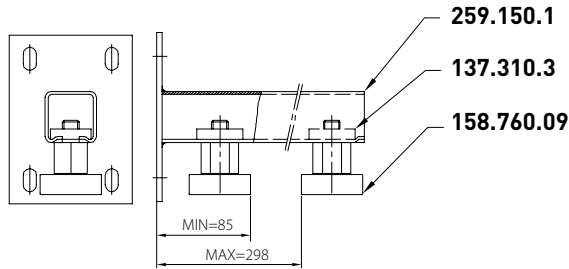

Zij worden aangebracht in een aangepast U-profiel dat aan de muur wordt vastgeschroefd of in de muur wordt ingemetseld. Met deze beugels is een regeling mogelijk van de geleidrollen in functie van de dikte van het hek. Voor extra zware hekken dient een speciale geleider voorzien te worden. Gelieve ons hiervoor te contacteren.



259.250/1
(inclusief draagstukken 137.310.3)

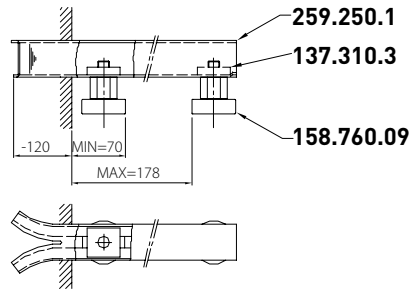

Op elk uiteinde van het profiel moet een eindstopper geplaatst worden zodat het profiel onmogelijk kan vrijkomen. Bij lange en/of zware hekken is het wenselijk om aan beide uiteinden van het profiel een eindstop met steunrol te gebruiken. In open en in gesloten stand zullen deze steunrollen niet alleen het doorbuigen van het hek opvangen, maar ook voor een groot deel de belasting op de beide rollen verminderen.



158.755 (Ø 50mm)
158.765 (Ø 60mm)

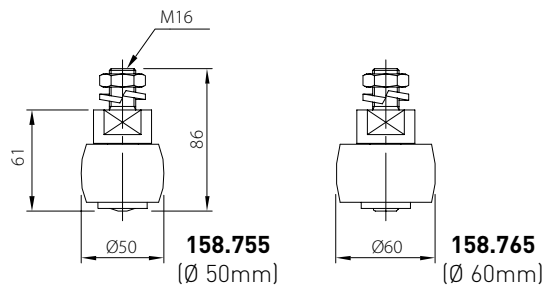

249.610
259.610
269.610

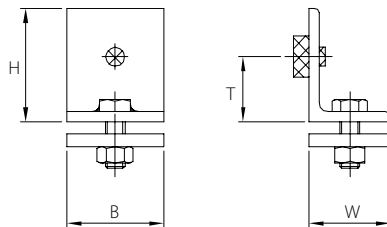

Ref.	T (mm)	B (mm)	H (mm)	W (mm)	Gewicht (kg)
249.610	30	40	60	56	0,450
259.610	40	50	70	60	0,600
269.610	58	65	90	75	1,200



249.660
259.660
269.660

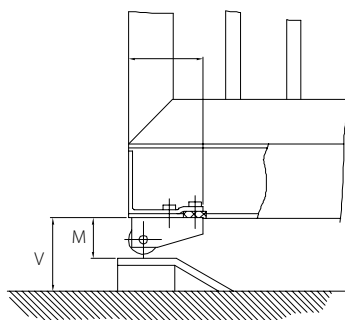

Ref.	V (mm)	M (mm)	N (mm)	Gewicht (kg)
249.660	90	50	95	1,750
259.660	90	50	105	1,750
269.660	110	70	135	1,750

B < 3000mm - 1 x 269.660
- 1 x 269.610
B > 3000mm - 2 x 269.660

LEVERBARE LENGTEN

3-4-5-6-7-8m

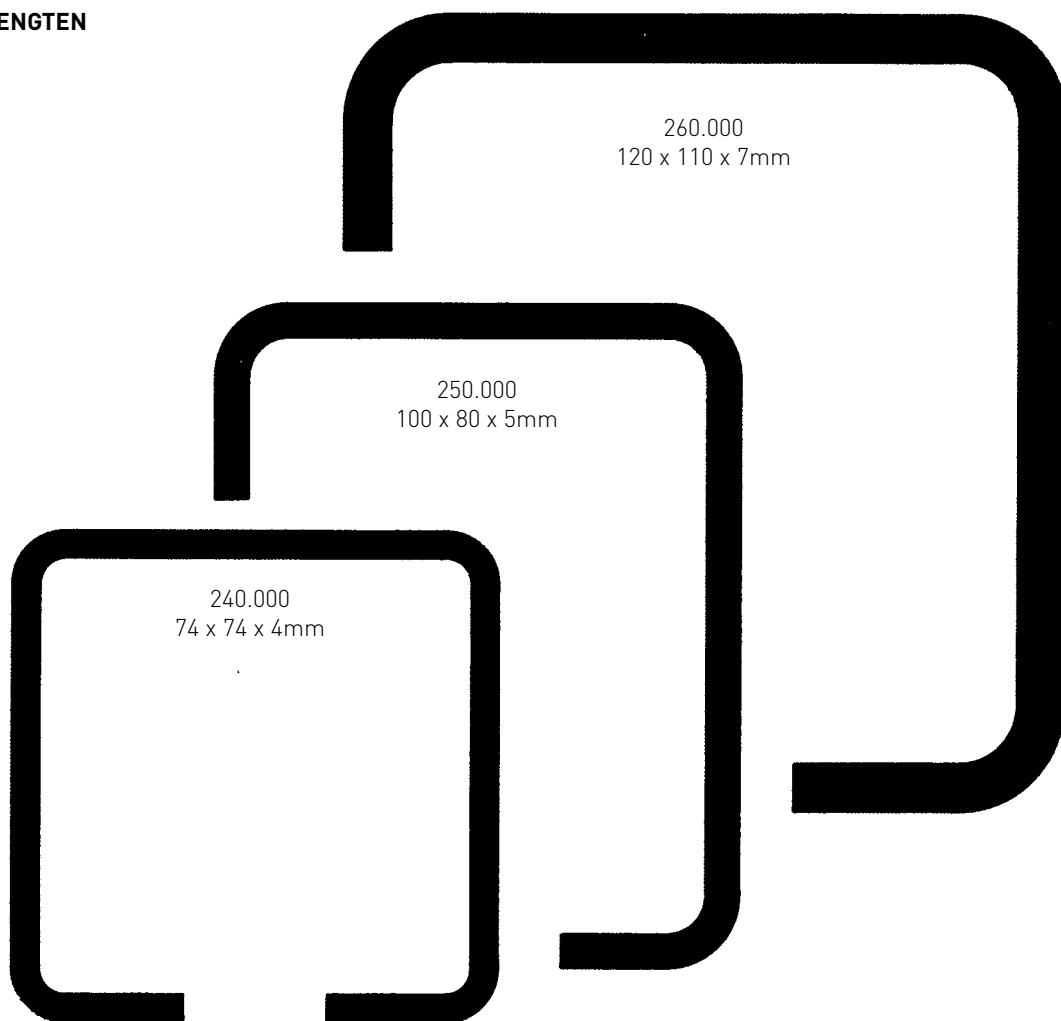

KARAKTERISTIEKEN

Profiel-Type	Afmetingen A x B x C mm	Gewicht Kg/m	S cm ²	Ix cm ⁴	V ₁ cm	V cm	$\frac{Ix}{V}$ cm ³	Z mm	r mm
240.000	74 x 74 x 4	7,67	9,84	72,5	4,01	3,40	18,0	22	5
250.000	100 x 80 x 5	11,55	14,80	186	5,39	4,60	34,5	26	7
260.000	120 x 110 x 7	21,00	26,90	501	6,42	5,58	78	28	9

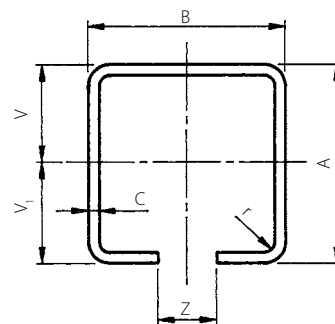

Alle profielen kunnen geleverd worden, brut(2), met een laag grondverf (6) of warm verzinkt (8). Brute profielen zijn te verkiezen voor het eventuele lassen van het profiel. Indien men daarna het hek warm verzinkt, dient men er voor te zorgen dat de loopweg over de ganse lengte zuiver en effen blijft. Bouten van het profiel behoort ook tot de mogelijkheden (zie pagina 7).

Hoe het gewenste profiel aanduiden:

- Nr. 240.000.300.2 : profiel type 240.000, lengte 3m - brut.
- Nr. 250.000.500.6 : profiel type 250.000, lengte 5m - grondverf.
- Nr. 260.000.800.8 : profiel type 260.000, lengte 8m - warm verzinkt.

BEVESTIGINGSMOGELIJKHEDEN

Er bestaan diverse mogelijkheden om het profiel stevig aan het hek te bevestigen:

- door het te lassen (hierbij dient men afwisselend beide zijden te lassen teneinde kromtrekken van het profiel te vermijden).
- door het te bouten (de te voorziene bouten en bijhorend plat ijzer in functie van het gekozen profieltype vindt men in de tabel).
- door middel van het profiel met opgezette bevestigingsstukken (voornamelijk bij houten hek).

Het bestelnummer van een profiel met opgezette bevestigingsstukken is hetzelfde als een gewoon profiel (zie pagina 6), behalve dat de 2e groep van drie cijfers "000" vervangen wordt door "190". Voorbeeld : 250.190.700.2 : 7 meter profiel 250.000 met bevestigingsstukken afwerking brut.

Daar het loopprofiel juist dezelfde lengte moet hebben als het hek, kan de afstand van het laatste bevestigingsstuk tot het einde van het hek te groot worden (zie tekening onderaan: A max. 200mm). Een beugel met bevestigingsstuk Nr. 241.890.000.X (251.890.000.X / 261.890.000.X) is in dit geval noodzakelijk. De letter "X" in het nummer staat voor de afwerking, te weten brut (X=2), met een laag grondverf (X=6) of warm gegalvaniseerd (X=8).

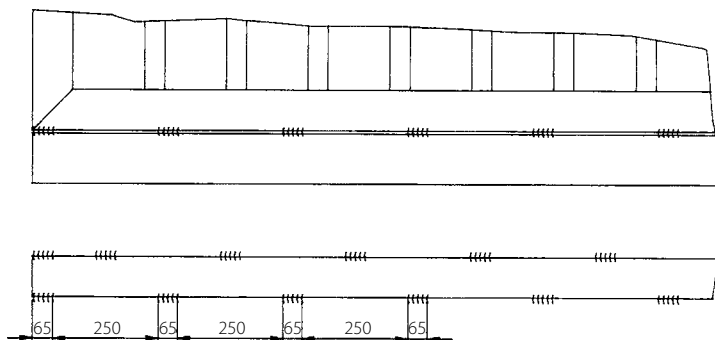
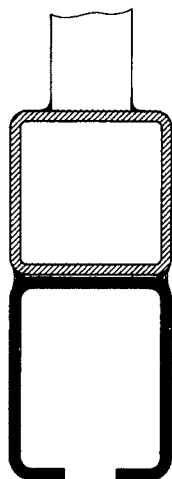

	B	H	Plat ijzer	Bout	Ø Kop	Hoogte kop
240.000	30	7,5	50/6 of 50/8	Lage cilinderschroef binnenzeskant Din 7984. M8 X 20	13	5
250.000	28	19	50/10	Lage cilinderschroef binnenzeskant Din 912. M12 X 25	18	12
260.000	30	27	60/12	Lage cilinderschroef binnenzeskant Din 912. M14 X 30	21	14

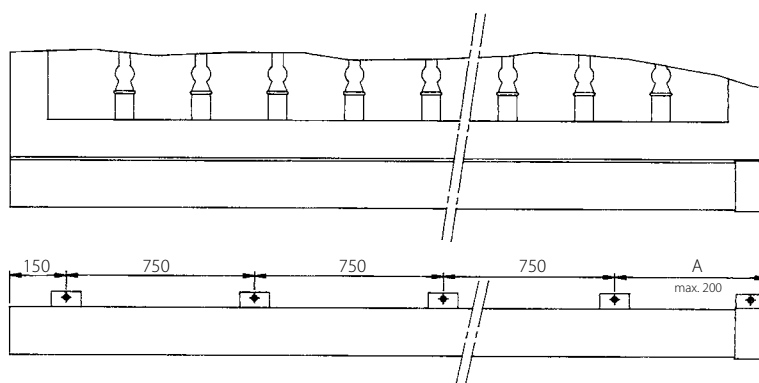
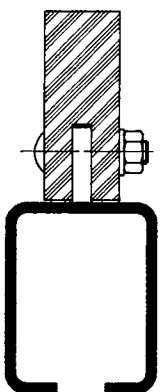
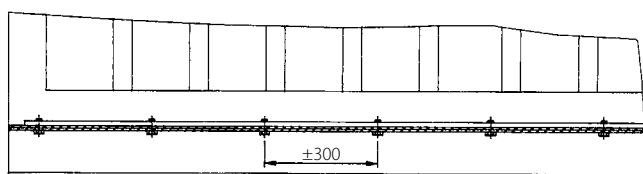
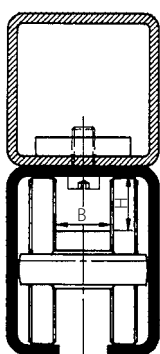

241.890.000.X
251.890.000.X
261.890.000.X

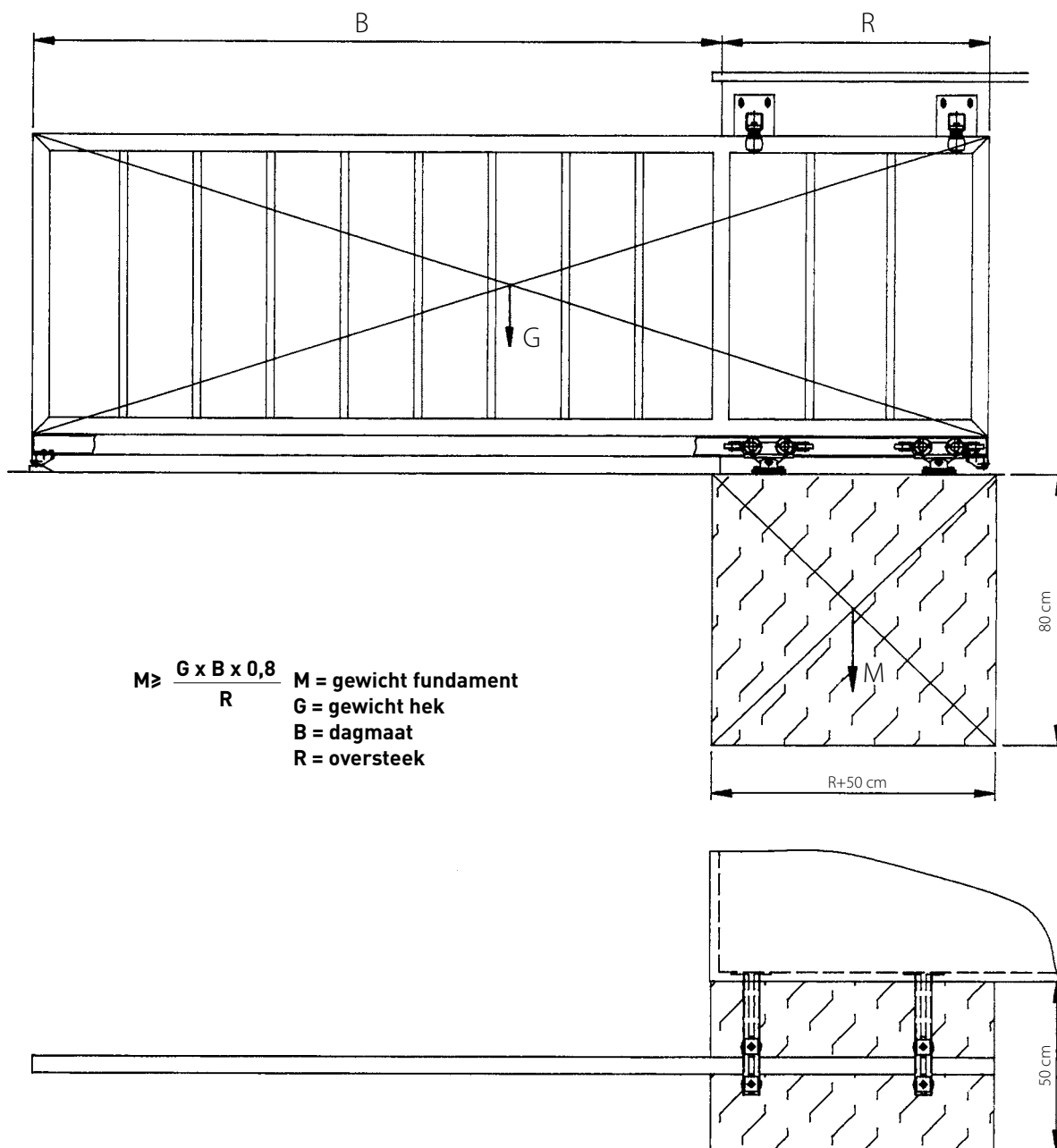

De goede werking van een zelfdragend schuifhek steunt voornamelijk op de juiste keuze van profiel en draagrollen, en op een stevige en verzorgde bevestiging van beide rolstelsels. Een stevige ondergrond (vb. beton (vorstvrij)) is absoluut noodzakelijk. In elk geval dient men er over te waken dat bovenstaande formule altijd toegepast wordt.

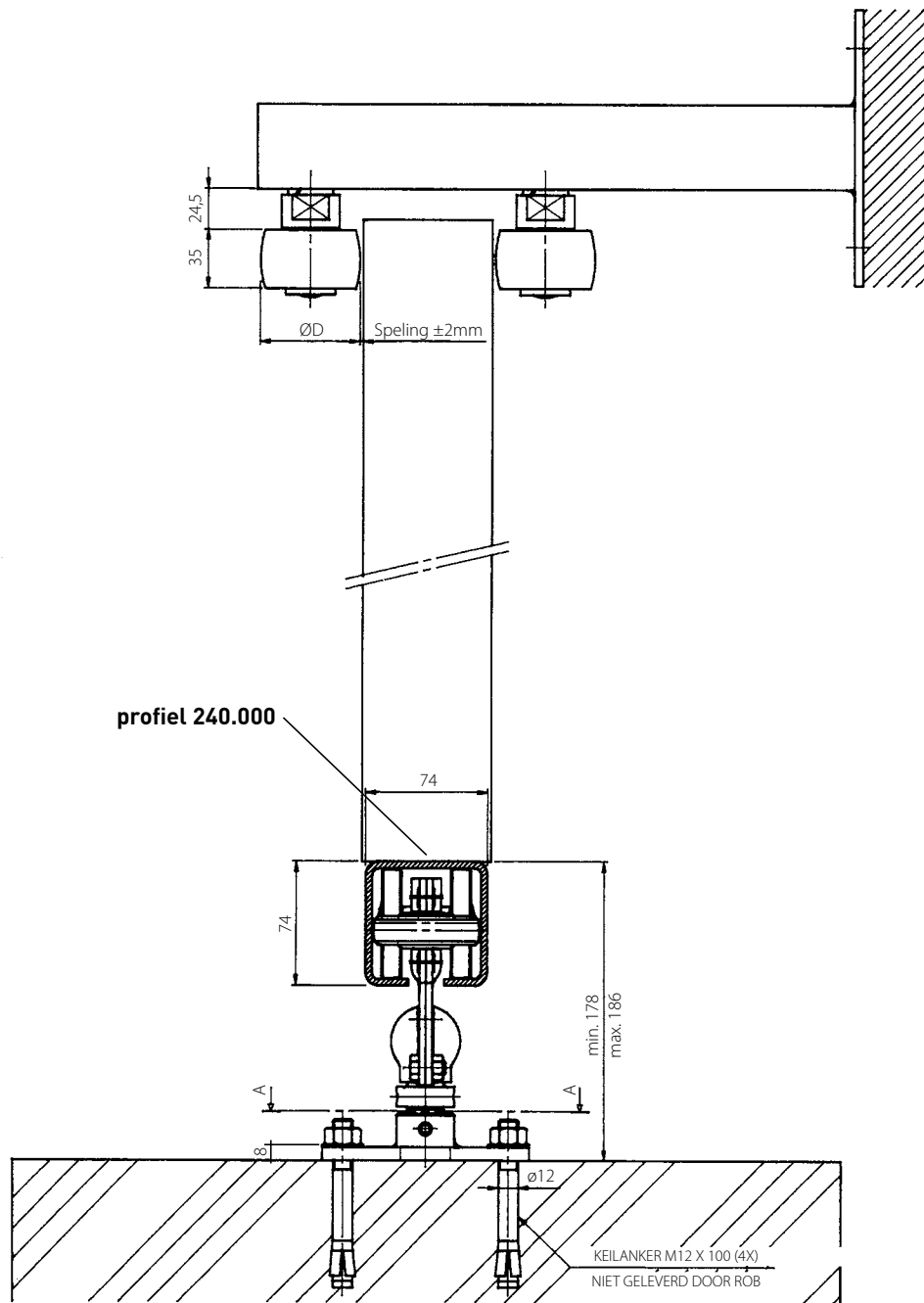

Doorsnede A-A

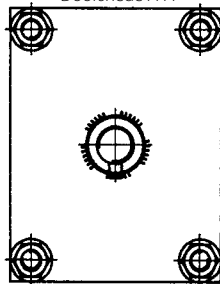

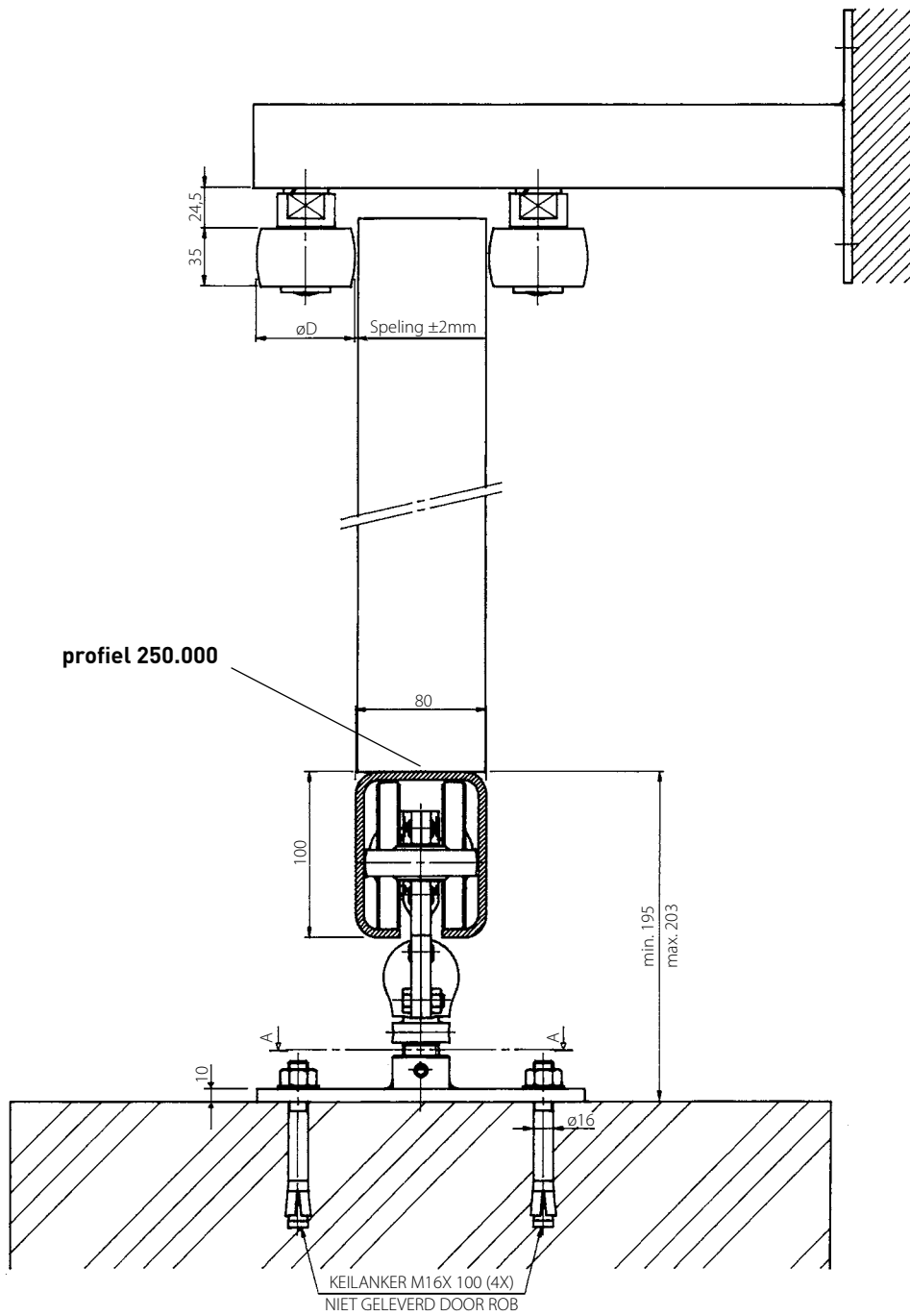

profiel 250.000

doorsnede A-A

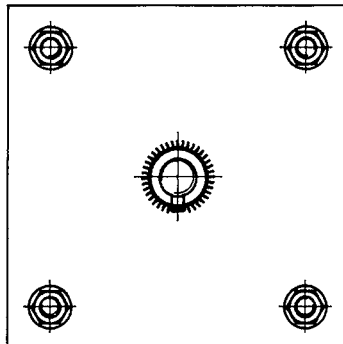

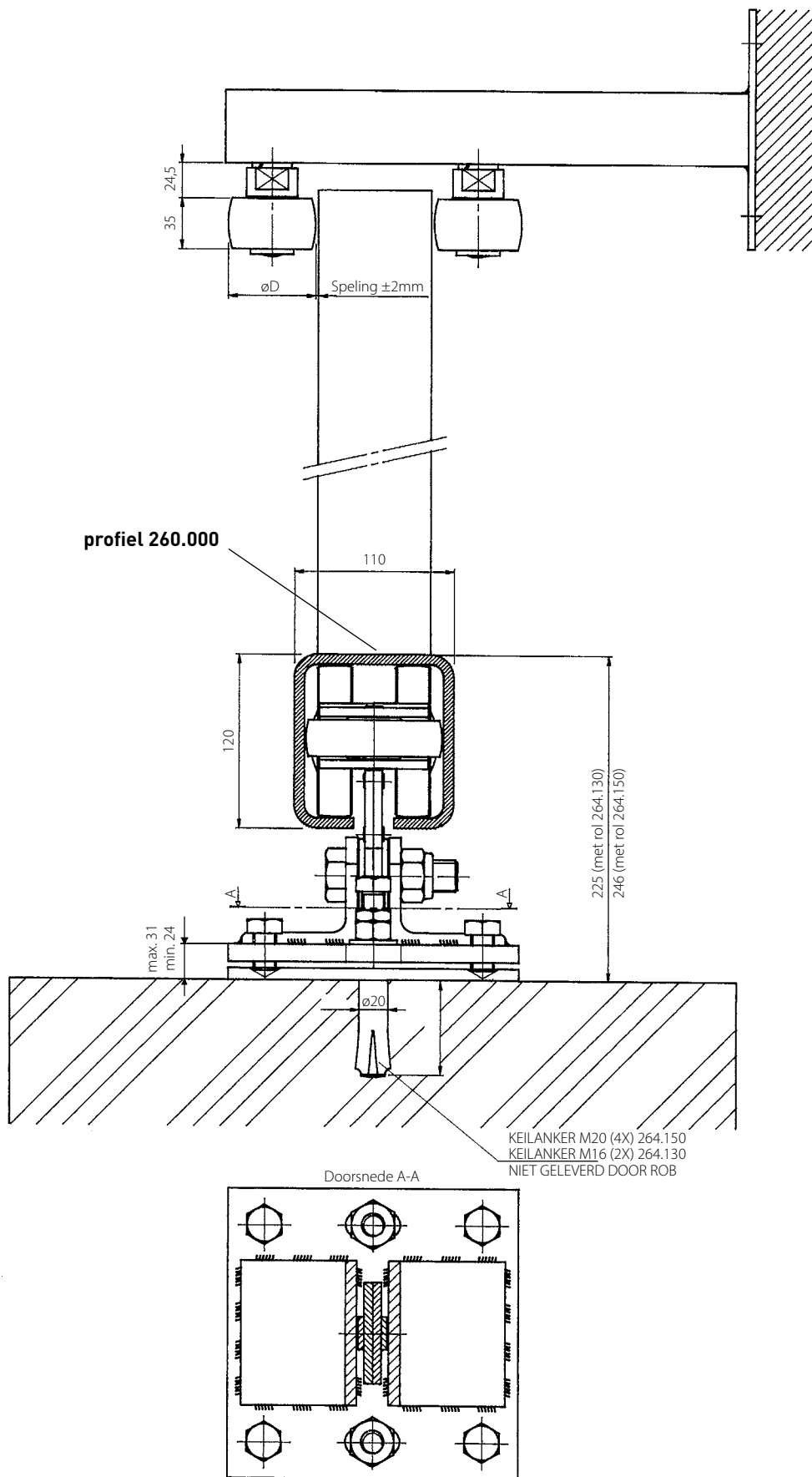

TABELLEN : zie p. 14-21

BELASTINGSCOËFFICIËNT: Kb

$$K_b = \frac{\text{totaal gewicht hek}}{\text{max toelaatbaar totaal gewicht}} \quad \text{of} \quad K_b = \frac{\text{werkbelasting rol}}{\text{max toelaatbare rolbelasting}}$$

Richtwaarden Kb	Aard van belasting	Aantal cyclussen per dag
1	normaal gebruik	max 15
0,8	intensief gebruik	15 à 50
0,6	zeer intensief gebruik	50 à 100
0,5	uitzonderlijk	100 à 150

De tabellen op de volgende bladzijden geven het totaalgewicht van het hek + het roltype en dit voor verschillende hoogten. De laatste kolom geeft het maximum toelaatbaar totaal gewicht van het hek. Voor eenzelfde dagmaat B zijn (vanaf 2500) meerdere oversteken R opgenomen zodat een keuze volgens grootte van de belastingscoëfficiënt mogelijk is.

Voorbeeld:

	B	R	Hoogte 1,65m	Max toel. gew.	Belast.coëf. Kb	Gebruik
1	2500	1050	152 Kg/244.130	158 Kg	152:158=0,96	normaal
2	2500	1300	159 Kg/244.130	233 Kg	159:233=0,68	intensief

DOORBUIGEN EN CONSTRUCTIE HEK:

Bij een zelfdragend hek moet het hekwerk zelf voldoende stevigheid hebben om samen met het profiel het hek in rechte lijn te houden. De tabellen van de hekconstructies bevatten richtgegevens om een aanvaardbare doorbuiging van het hek te bekomen. Het hek moet altijd winddoorlatend zijn. Percentage winddoorlaatbaarheid : min. 65 à 70%

VERKLARING SYMBOLEN TABELLEN:

Bv. :

B = 2000
R = 1050

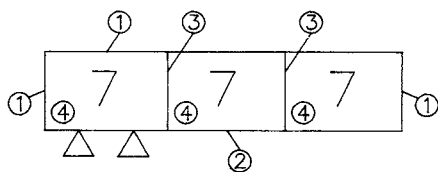

Bovenkader = ① → 60/60/3
Onderkader = ② → 60/60/3
Stijlen = ③ → 60/60/3
Vulling = ④ → 30/20/2
Aantal = **7**

B = 6500
R = 2050

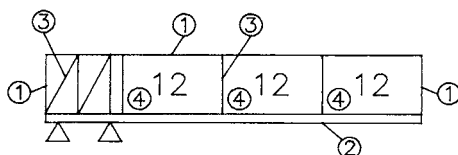

Bovenkader = ① → 80/80/3
Onderkader = ② → 120/80/3
Stijlen = ③ → 80/80/3
Vulling = ④ → 40/40/2
Aantal = **12**

B = 8500
R = 3000

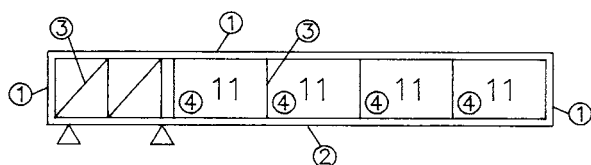

Bovenkader = ① → 120/80/3
Onderkader = ② → 120/80/3
Stijlen = ③ → 80/80/3
Vulling = ④ → 40/40/2
Aantal = **11**

RICHTWAARDEN HEKCONSTRUCTIE

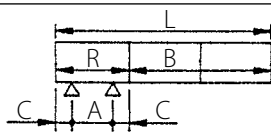
Dagmaat B	Oversteek R	Totale lengte L	Constructie hek		Kader								
2000	1050	3050	<table border="1"><tr><td>7</td><td>7</td><td>7</td></tr><tr><td>Δ</td><td>Δ</td><td></td></tr></table>	7	7	7	Δ	Δ			① ② ③ 60/60/3		
7	7	7											
Δ	Δ												
2250	1050	3300	<table border="1"><tr><td>7</td><td>8</td><td>8</td></tr><tr><td>Δ</td><td>Δ</td><td></td></tr></table>	7	8	8	Δ	Δ			① ② ③ 60/60/3		
7	8	8											
Δ	Δ												
2500	1050	3550	<table border="1"><tr><td>7</td><td>9</td><td>9</td></tr><tr><td>Δ</td><td>Δ</td><td></td></tr></table>	7	9	9	Δ	Δ			① ② ③ 60/60/3		
7	9	9											
Δ	Δ												
2500	1300	3800	<table border="1"><tr><td>9</td><td>9</td><td>9</td></tr><tr><td>Δ</td><td>Δ</td><td></td></tr></table>	9	9	9	Δ	Δ			① ② ③ 60/60/3		
9	9	9											
Δ	Δ												
2750	1050	3800	<table border="1"><tr><td>7</td><td>10</td><td>10</td></tr><tr><td>Δ</td><td>Δ</td><td></td></tr></table>	7	10	10	Δ	Δ			① ② ③ 60/60/3		
7	10	10											
Δ	Δ												
2750	1300	4050	<table border="1"><tr><td>9</td><td>10</td><td>10</td></tr><tr><td>Δ</td><td>Δ</td><td></td></tr></table>	9	10	10	Δ	Δ			① ② ③ 60/60/3		
9	10	10											
Δ	Δ												
3000	1050	4050	<table border="1"><tr><td>7</td><td>7</td><td>7</td><td>7</td></tr><tr><td>Δ</td><td>Δ</td><td></td><td></td></tr></table>	7	7	7	7	Δ	Δ				① ② ③ 60/60/3
7	7	7	7										
Δ	Δ												
3000	1300	4300	<table border="1"><tr><td>9</td><td>7</td><td>7</td><td>7</td></tr><tr><td>Δ</td><td>Δ</td><td></td><td></td></tr></table>	9	7	7	7	Δ	Δ				① ② ③ 60/60/3
9	7	7	7										
Δ	Δ												
3000	1550	4550	<table border="1"><tr><td>10</td><td>7</td><td>7</td><td>7</td></tr><tr><td>Δ</td><td>Δ</td><td></td><td></td></tr></table>	10	7	7	7	Δ	Δ				① ② ③ 60/60/3
10	7	7	7										
Δ	Δ												
3250	1050	4300	<table border="1"><tr><td>7</td><td>7</td><td>7</td><td>7</td></tr><tr><td>Δ</td><td>Δ</td><td></td><td></td></tr></table>	7	7	7	7	Δ	Δ				① ② ③ 60/60/3
7	7	7	7										
Δ	Δ												
3250	1300	4550	<table border="1"><tr><td>8</td><td>10</td><td>10</td></tr><tr><td>Δ</td><td>Δ</td><td></td></tr></table>	8	10	10	Δ	Δ			① ② ③ 80/80/3		
8	10	10											
Δ	Δ												
3250	1550	4800	<table border="1"><tr><td>9</td><td>10</td><td>10</td></tr><tr><td>Δ</td><td>Δ</td><td></td></tr></table>	9	10	10	Δ	Δ			① ② ③ 80/80/3		
9	10	10											
Δ	Δ												
3500	1300	4800	<table border="1"><tr><td>8</td><td>7</td><td>7</td><td>7</td></tr><tr><td>Δ</td><td>Δ</td><td></td><td></td></tr></table>	8	7	7	7	Δ	Δ				① ② ③ 80/80/3
8	7	7	7										
Δ	Δ												
3500	1550	5050	<table border="1"><tr><td>9</td><td>7</td><td>7</td><td>7</td></tr><tr><td>Δ</td><td>Δ</td><td></td><td></td></tr></table>	9	7	7	7	Δ	Δ				① ② ③ 80/80/3
9	7	7	7										
Δ	Δ												
3500	1800	5300	<table border="1"><tr><td>11</td><td>7</td><td>7</td><td>7</td></tr><tr><td>Δ</td><td>Δ</td><td></td><td></td></tr></table>	11	7	7	7	Δ	Δ				① ② ③ 80/80/3
11	7	7	7										
Δ	Δ												
3750	1300	5050	<table border="1"><tr><td>8</td><td>7</td><td>7</td><td>7</td></tr><tr><td>Δ</td><td>Δ</td><td></td><td></td></tr></table>	8	7	7	7	Δ	Δ				① ② ③ 80/80/3
8	7	7	7										
Δ	Δ												
3750	1550	5300	<table border="1"><tr><td>9</td><td>7</td><td>7</td><td>7</td></tr><tr><td>Δ</td><td>Δ</td><td></td><td></td></tr></table>	9	7	7	7	Δ	Δ				① ② ③ 80/80/3
9	7	7	7										
Δ	Δ												
3750	1800	5550	<table border="1"><tr><td>11</td><td>7</td><td>7</td><td>7</td></tr><tr><td>Δ</td><td>Δ</td><td></td><td></td></tr></table>	11	7	7	7	Δ	Δ				① ② ③ 80/80/3
11	7	7	7										
Δ	Δ												

Vulling	Profiel n° ↓ ↘ Hoogte zonder profiel →	Totaal gewicht van hek (profiel inbegrepen) (kg)					Roltype					max. tot. gewicht
		1,05 m		1,25 m		1,45 m		1,65 m		1,85 m		
30/20/2	240.000	104	244.130	114	244.130	124	244.130	134	244.130	144	244.130	190 kg
30/20/2	240.000	111	244.130	122	244.130	133	244.130	144	244.130	155	244.130	172 kg
30/20/2	240.000	118	244.130	129	244.130	140	244.130	152	244.130	164		158 kg
	250.000									179	254.130	316 kg
30/20/2	240.000	123	244.130	135	244.130	147	244.130	159	244.130	171	244.130	223 kg
30/20/2	240.000	125	244.130	137	244.130							145 kg
	250.000			153	254.130	165	254.130	177	254.130	189	254.130	290 kg
30/20/2	240.000	130	244.130	143	244.130	156	244.130	169	244.130	182	244.130	207 kg
30/20/2												
	250.000	152	254.130	166	254.130	178	254.130	191	254.130	205	254.130	270 kg
30/20/2	240.000	143	244.130	157	244.130	171	244.130	185	244.130	199		193 kg
	250.000									216	254.130	386 kg
30/20/2	240.000	149	244.130	163	244.130	177	244.130	191	244.130	205	244.130	230 kg
30/20/2												
	250.000	160	254.130	174	254.130	188	254.130	202	254.130	216	254.130	252 kg
of 40/20/2 30/30/2	240.000	162	244.130	175	244.130	189						181 kg
	250.000					207	254.130	218	254.130	231	254.130	362 kg
of 40/20/2 30/30/2	240.000	168	244.130	181	244.130	194	244.130	207	244.130	220	244.130	244 kg
of 40/20/2 30/30/2	240.000	178										170 kg
	250.000	200	254.130	216	254.130	232	254.130	248	254.130	265	254.130	341 kg
of 40/20/2 30/30/2	240.000	189	244.130	206	244.130	223						217 kg
	250.000					244	254.130	260	254.130	276	254.130	434 kg
of 40/20/2 30/30/2	240.000	197	244.130	214	244.130	232	244.130	249	244.130			258 kg
	250.000							269	254.130	287	254.130	516 kg
of 40/20/2 30/30/2												
	250.000	208	254.130	225	254.130	242	254.130	259	254.130	276	254.130	322 kg
of 40/20/2 30/30/2	240.000											205 kg
	250.000	216	254.130	233	254.130	250	254.130	267	254.130	284	254.130	410 kg
of 40/20/2 30/30/2	240.000	205	244.130	222	244.130	240	244.130	257				245 kg
	250.000							278	254.130	296	254.130	490 kg

RICHTWAARDEN HEKCONSTRUCTIE

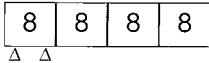
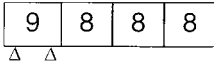
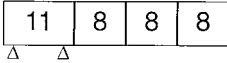
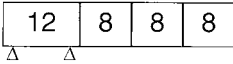
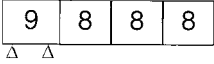
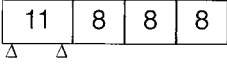
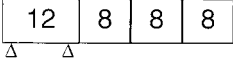
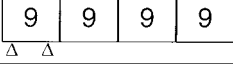
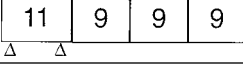
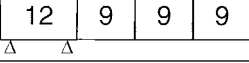
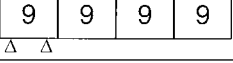
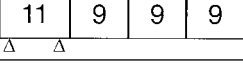
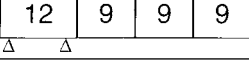
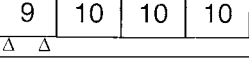
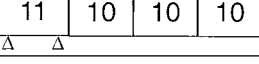
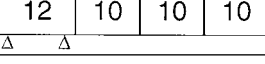
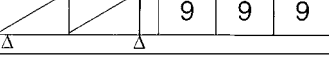
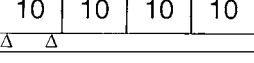
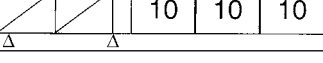
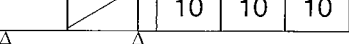
Dagmaat B	Oversteek R	Totale lengte L	Constructie hek	Kader
4000	1300	5300		①②③ 80/80/3
4000	1550	5550		①②③ 80/80/3
4000	1800	5800		①②③ 80/80/3
4000	2050	6050		①②③ 80/80/3
4250	1550	5800		①②③ 80/80/3
4250	1800	6050		①②③ 80/80/3
4250	2050	6300		①②③ 80/80/3
4500	1550	6050		①②③ 80/80/3
4500	1800	6300		①②③ 80/80/3
4500	2050	6550		①②③ 80/80/3
4750	1550	6300		①②③ 80/80/3
4750	1800	6550		①②③ 80/80/3
4750	2050	6800		①②③ 80/80/3
5000	1550	6550		①②③ 80/80/3
5000	1800	6800		①②③ 80/80/3
5000	2050	7050		①②③ 80/80/3
5000	2500	7500		①②③ 80/80/3
5500	1800	7300		①②③ 80/80/3
5500	2050	7550		①②③ 80/80/3
5500	2500	8000		①②③ 80/80/3

Vulling	Profiel n° ↓ ↗ Hoogte zonder profiel	Totaal gewicht van hek (profiel inbegrepen) (kg)						Roltype					max. tot. gewicht
		1,05 m		1,25 m		1,45 m		1,65 m		1,85 m			
of	40/20/2	240.000											152 kg
	30/30/2	250.000	219	254.130	237	254.130	255	254.130	273	254.130	291	254.130	305 kg
of	40/20/2	240.000											195 kg
	30/30/2	250.000	227	254.130	245	254.130	263	254.130	281	254.130	299	254.130	390 kg
of	40/20/2	240.000	215	244.130	235								234 kg
	30/30/2	250.000			257	254.130	275	254.130	294	254.130	313	254.130	467 kg
of	40/20/2	240.000	221	244.130	240	244.130	259	244.130	278				268 kg
	30/30/2	250.000							302	254.130	321	254.130	537 kg
of	40/20/2	240.000											185 kg
	30/30/2	250.000	234	254.130	252	254.130	270	254.130	289	254.130	307	254.130	371 kg
of	40/20/2	240.000											223 kg
	30/30/2	250.000	244	254.130	263	254.130	282	254.130	301	254.130	320	254.130	446 kg
of	40/20/2	240.000	228	244.130	247	244.130	266						256 kg
	30/30/2	250.000					291	254.130	310	254.130	329	254.130	513 kg
of	40/20/2	240.000											177 kg
	30/30/2	250.000	245	254.130	264	254.130	283	254.130	303	254.130	322	254.130	354 kg
of	40/20/2	240.000											213 kg
	30/30/2	250.000	255	254.130	275	254.130	295	254.130	315	254.130	335	254.130	426 kg
of	40/20/2	240.000	236	244.130	255								245 kg
	30/30/2	250.000			284	254.130	303	254.130	322	254.130	341	254.130	492 kg
of	40/20/2	240.000											169 kg
	30/30/2	250.000	252	254.130	271	254.130	290	254.130	310	254.130	330	254.130	339 kg
of	40/20/2	240.000											204 kg
	30/30/2	250.000	261	254.130	281	254.130	301	254.130	321	254.130	341	254.130	408 kg
of	40/20/2	240.000											236 kg
	30/30/2	250.000	269	254.130	289	254.130	309	254.130	329	254.130	349	254.130	472 kg
of	40/20/2	250.000	260	254.130	280	254.130	301	254.130	321	254.130	342		324kg
	30/30/2	260.000								403	264.130		648 kg
of	40/20/2	240.000											196 kg
	30/30/2	250.000	272	254.130	293	254.130	314	254.130	335	254.130	356	254.130	392 kg
of	40/20/2	240.000											227 kg
	30/30/2	250.000	281	254.130	302	254.130	323	254.130	344	254.130	365	254.130	454 kg
	40/20/2	240.000											277 kg
		250.000	314	254.130	339	254.130	364	254.130	389	254.130	414	254.130	555 kg
	40/20/2	250.000	305	254.130	328	254.130	351	254.130	374				363 kg
		260.000							443	264.130	466	264.130	726 kg
	40/20/2	250.000	331	254.130	354	254.130	377	254.130	400	254.130	423		422 kg
		260.000									494	264.130	844 kg
	40/20/2	250.000	335	254.130	360	254.130	386	254.130	413	254.130	439	254.130	517 kg

RICHTWAARDEN HEKCONSTRUCTIE

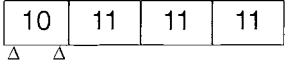
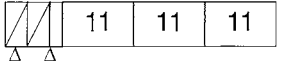
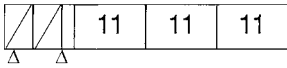
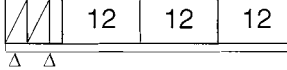
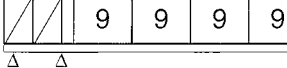
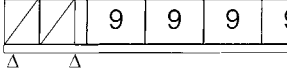
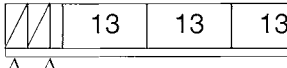
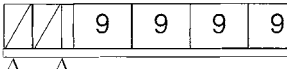
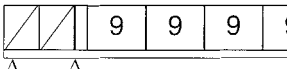
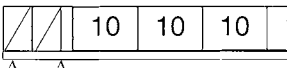
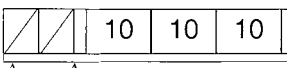
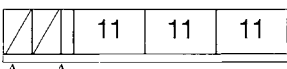
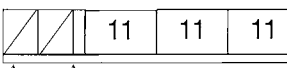
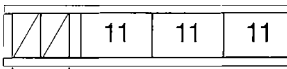
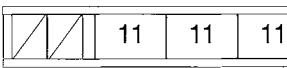
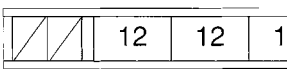
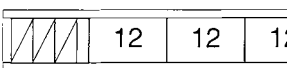
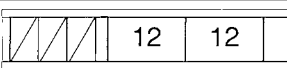
Dagmaat B	Oversteek R	Totale lengte L	Constructie hek	Kader
6000	1800	7800		① ② ③ 80/80/3
6000	2050	8050		① ② ③ 80/80/3
6000	2500	8500		① ② ③ 80/80/3
6500	2050	8550		① 80/80/3 ② 120/80/3 ③ 80/80/3
6500	2500	9000		① 80/80/3 ② 120/80/3 ③ 80/80/3
6500	3000	9500		① 80/80/3 ② 120/80/3 ③ 80/80/3
7000	2050	9050		① 80/80/3 ② 120/80/3 ③ 80/80/3
7000	2500	9500		① 80/80/3 ② 120/80/3 ③ 80/80/3
7000	3000	10000		① 80/80/3 ② 120/80/3 ③ 80/80/3
7500	2500	10000		① 80/80/3 ② 120/80/3 ③ 80/80/3
7500	3000	10500		① 80/80/3 ② 120/80/3 ③ 80/80/3
8000	2500	10500		① 80/80/3 ② 120/80/3 ③ 80/80/3
8000	3000	11000		① 80/80/3 ② 120/80/3 ③ 80/80/3
8500	3000	11500		① 120/80/3 ② 120/80/3 ③ 80/80/3
8500	3500	12000		① 120/80/3 ② 120/80/3 ③ 80/80/3
9000	3000	12000		① 120/80/3 ② 120/80/3 ③ 80/80/3
9000	3500	12500		① 120/80/3 ② 120/80/3 ③ 80/80/3
9000	4000	13000		① 120/80/3 ② 120/80/3 ③ 80/80/3

Vulling	Profiel n° ↓ Hoogte zonder profiel →	Totaal gewicht van hek (profiel inbegrepen) (kg)						Roltype					max. tot. gewicht
		1,05 m		1,25 m		1,45 m		1,65 m		1,85 m			
40/40/2	250.000	327	254.130	352								338 kg	
	260.000			426	264.130	451	264.130	476	264.130	501	264.130	676 kg	
40/40/2	250.000	356	254.130	370	254.130	404						393 kg	
	260.000					480	264.130	505	264.130	530	264.130	786 kg	
40/40/2	250.000	357	254.130	384	254.130	410	254.130	437	254.130	464	254.130	484 kg	
	260.000											969 kg	
40/40/2	250.000											368 kg	
	260.000	445	264.130	481	264.130	507	264.130	533	264.130	559	264.130	737 kg	
40/40/2	250.000	361	254.130	391	254.130	421						406 kg	
	260.000					516	264.130	547	264.130	577	264.130	912 kg	
40/40/2	250.000	374	254.130	407	254.130	439	254.130	472	254.130	504	254.130	542 kg	
	260.000											1085 kg	
40/40/2													
	260.000	490	264.130	517	264.130	544	264.130	571	264.130	598	264.130	694 kg	
40/40/2	250.000	376	254.130	406	254.130	436						430 kg	
	260.000					526	264.130	557	264.130	588	264.130	860 kg	
40/40/2	250.000	388	254.130	420	254.130	453	254.130	485	254.130	518		513 kg	
	260.000									613	264.130	1027 kg	
40/40/2	250.000	397	254.130	430								407 kg	
	260.000			523	264.130	556	264.130	589	264.130	621	264.130	815 kg	
40/40/2	250.000	408	254.130	443	254.130	478	254.130	513				487 kg	
	260.000							611	264.130	647	264.130	975 kg	
40/40/2	250.000											387 kg	
	260.000	517	264.130	554	264.130	586	264.130	621	264.130	655	264.130	774 kg	
40/40/2	250.000	430	254.130	467								464 kg	
	260.000			571	264.130	608	264.130	645	264.130	682	264.130	928 kg	
40/40/2	260.000	595	264.130	632	264.130	669	264.130	706	264.130	743	264.130	886 kg	
40/40/2	260.000	630	264.130	669	264.130	707	264.130	746	264.130	784	264.130	1022 kg	
40/40/2	260.000	623	264.130	662	264.130	700	264.130	740	264.130	778	264.130	847 kg	
40/40/2	260.000	656	264.130	697	264.130	738	264.130	780	264.130	819	264.130	980 kg	
40/40/2	260.000	690	264.130	728	264.130	765	264.130	803	264.130	840	264.130	1101 kg	

RICHTWAARDEN HEKCONSTRUCTIE

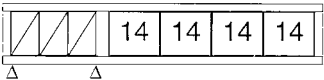
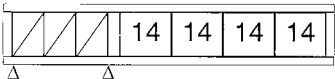
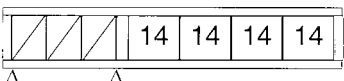
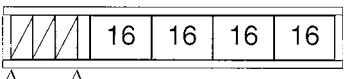
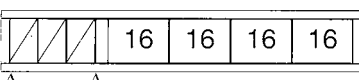
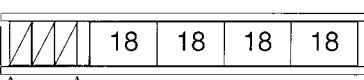
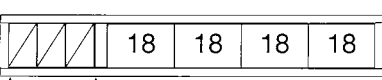
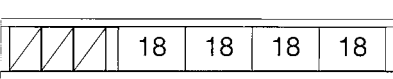
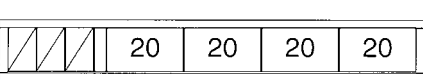
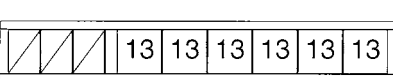
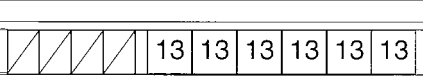
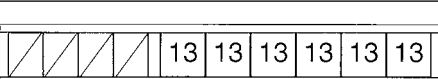
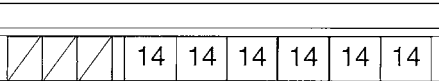
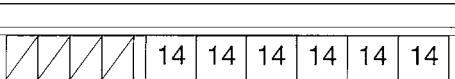
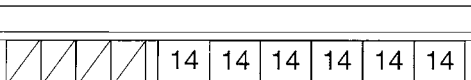
Dagmaat B	Oversteek R	Totale lengte L	Constructie hek	Kader
10000	3500	13500		① 120/80/3 ② 120/80/3 ③ 80/80/3
10000	4000	14000		① 120/80/3 ② 120/80/3 ③ 80/80/3
10000	4500	14500		① 120/80/3 ② 120/80/3 ③ 80/80/3
11000	4000	15000		① 150/100/4 ② of 160/80/4 ③ 80/80/3
11000	4500	15500		① 150/100/4 ② of 160/80/4 ③ 80/80/3
12000	4000	16000		① 150/100/4 ② 150/100/4 ③ 80/80/3
12000	4500	16500		① 150/100/4 ② 150/100/4 ③ 80/80/3
12000	5000	17000		① 150/100/4 ② 150/100/4 ③ 80/80/3
13000	4500	17500		① 150/100/4 ② 150/100/4 ③ 80/80/3
13000	5000	18000		① 150/100/4 ② 150/100/4 ③ 100/100/3
13000	5500	18500		① 150/100/4 ② 150/100/4 ③ 100/100/3
13000	6000	19000		① 150/100/4 ② 150/100/4 ③ 100/100/3
14000	5000	19000		① 150/100/4 ② 150/100/4 ③ 100/100/3
14000	5500	19500		① 150/100/4 ② 150/100/4 ③ 100/100/3
14000	6000	20000		① 150/100/4 ② 150/100/4 ③ 100/100/3

Vulling	Profiel n° ↓ Hoogte zonder profiel →	Totaal gewicht van hek (profiel inbegrepen) (kg)						Roltype					max. tot. gewicht
		1,05 m		1,25 m		1,45 m		1,65 m		1,85 m			
40/40/2	260.000					800	264.130	840	264.130	880	264.130	904 kg	
	260.000												
40/40/2	260.000					815	264.130	855	264.130	895	264.130	1019 kg	
	260.000												
40/40/2	260.000					830	264.130	870	264.130	910	264.130	1126 kg	
	260.000												
40/40/2	260.000												
	260.000					1066	264.150	1110	264.150	1153	264.150	1714 kg	
40/40/2	260.000												
	260.000					1090	264.150	1139	264.150	1188	264.150	1930 kg	
40/40/2	260.000												
	260.000					1126	264.150	1180	264.150	1233	264.150	1600 kg	
40/40/2	260.000												
	260.000					1162	264.150	1220	264.150	1277	264.150	1806 kg	
40/40/2	260.000												
	260.000					1210	264.150	1268	264.150	1325	264.150	2000 kg	
40/40/2	260.000												
	260.000					1235	264.150	1296	264.150	1358	264.150	1696 kg	
40/40/2	260.000												
	260.000					1401	264.150	1462	264.150	1523	264.150	1882 kg	
40/40/2	260.000												
	260.000					1474	264.150	1547	264.150	1620	264.150	2057 kg	
40/40/2	260.000												
	260.000					1512	264.150	1585	264.150	1658	264.150	2222 kg	
40/40/2	260.000												
	260.000					1500	264.150	1576	264.150	1652	264.150	1777 kg	
40/40/2	260.000												
	260.000					1544	264.150	1620	264.150	1696	264.150	1946 kg	
40/40/2	260.000												
	260.000					1582	264.150	1658	264.150	1734	264.150	2105 kg	

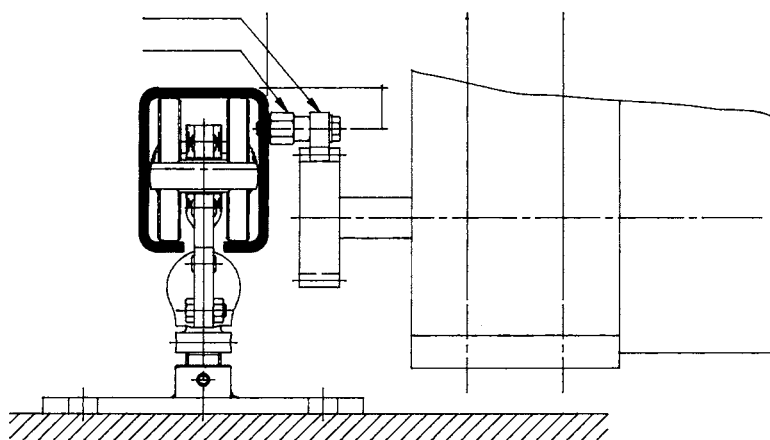
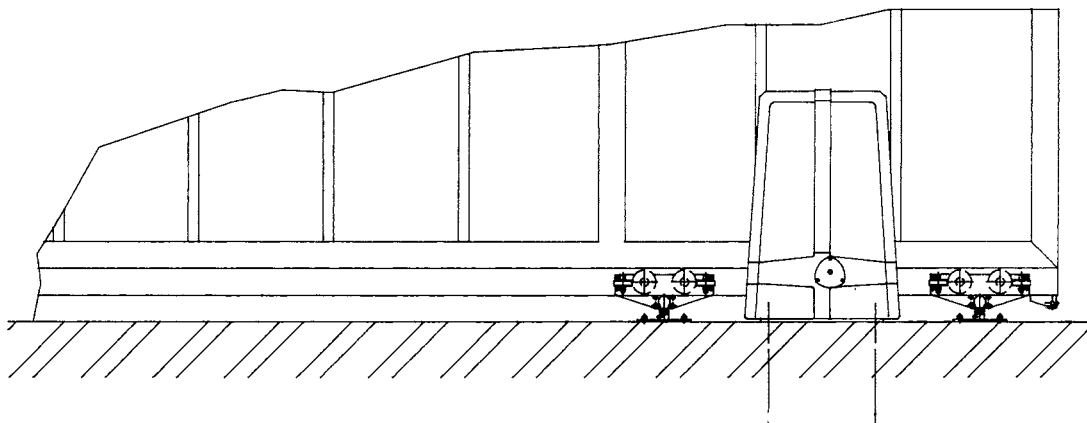
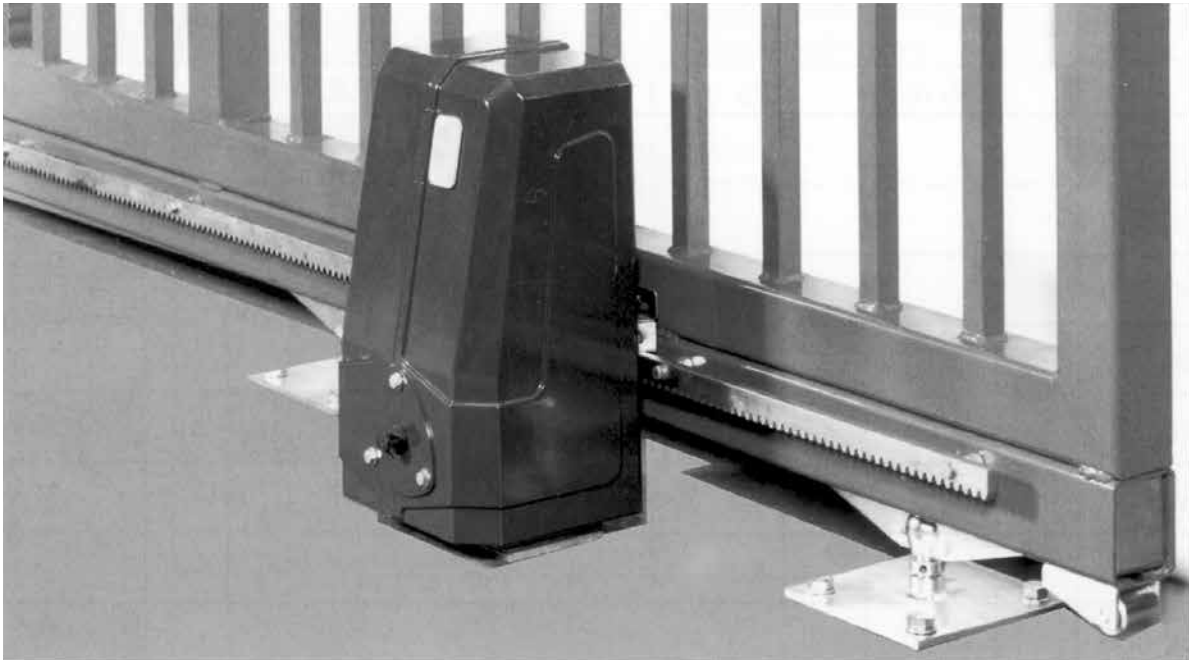

Een ROB zelfdragend schuifhek kan eenvoudig geautomatiseerd worden d.m.v. een aandrijving met tandlatten.
De motorgroep wordt geplaatst op een stevige voet tussen beide rolstelsels in.

SCHUIFDEURBESLAG VOOR BOUW EN INDUSTRIE

Rechtschuivend deurbeslag
Om de hoek schuivend deurbeslag
Vouwdeurbeslag
Aluminiumbeslag voor vouwdeuren
Harmonicadeurbeslag
Beslag voor zelfdragend schuifhek
Katrollen op as - hangrollen
Schuifsystemen voor luiken

BESLAG VOOR KANTELPOORTEN EN BI-SECTIONAALPOORTEN

Beslag voor kantelpoorten
Beslag voor bisectionaalpoorten

SCHUIFDEURBESLAG VOOR MEUBELN EN INTERIEUR

Schuifdeurbeslag voor meubelen
Garnituren voor schuifglas
EXPERT - schuifdeurbeslag voor het interieur
SYMFO schuifsystemen
Design schuifdeurbeslag
Pocket deur
Latent Pocket



Alle aanduidingen van maten en nummers zijn met de grootste zorg aangebracht. Voor eventuele foutieve aanduidingen kunnen wij niet verantwoordelijk zijn. Wij behouden het recht voor nummers, maten of modellen te wijzigen zonder voorafgaande vermelding.



LOUAGE & WISSELINCK

MAATSCHAPPELIJKE ZETEL
STATIONSTRAAT 221
8850 ARDOOIE
BELGIUM

COMMERCIELE DIENST
TER VLUCHT 2
8850 ARDOOIE
BELGIUM

WWW.ROB.BE
INFO@ROB.BE
TEL. +32 (0)51 74 48 01
FAX. +32 (0)51 74 48 05